

# electriQ

## USER AND INSTALLATION MANUAL



### FLOOR & CEILING MOUNTED DC INVERTER SPLIT AIR CONDITIONER WITH HEAT PUMP

eiQ-FC18K	18,000 BTU
eiQ-FC24K	24,000 BTU
eiQ-FC36K	36,000 BTU

Thank you for choosing electriQ  
Please read this user manual before using this innovative  
Air Conditioner and keep it safe for future reference.  
Visit our page [www.electriQ.co.uk](http://www.electriQ.co.uk) for our entire range of Intelligent Electricals

# CONTENTS

<b>CONTENTS</b>	<b>2</b>
<b>SAFETY INSTRUCTIONS</b>	<b>3</b>
<b>PRODUCT DESCRIPTION</b>	<b>4</b>
<b>HOW AIR SPLIT CONDITIONERS WORK</b>	<b>5</b>
<b>DISPLAY PANEL</b>	<b>7</b>
<b>REMOTE CONTROL</b>	<b>8</b>
<b>REPLACING THE BATTERIES</b>	<b>10</b>
<b>FILTERS</b>	<b>13</b>
<b>START OF SEASON</b>	<b>14</b>
<b>END OF SEASON</b>	<b>14</b>
<b>INSTALLATION GUIDE</b>	<b>15</b>
<b>TOOLS RECOMMENDED FOR INSTALLATION</b>	<b>18</b>
<b>INSTALLATION OF THE OUTDOOR UNIT</b>	<b>23</b>
<b>PIPELINES CONNECTION &amp; AIR PURGING</b>	<b>26</b>
<b>ELECTRICAL WIRING DIAGRAMS</b>	<b>30</b>
<b>TROUBLESHOOTING AND SELF DIAGNOSIS</b>	<b>32</b>
<b>TECHNICAL SPECIFICATIONS</b>	<b>36</b>
<b>APPENDIX</b>	<b>39</b>

## SAFETY INSTRUCTIONS

### Important!

- Carefully read the instructions before operating the unit.
- This appliance comprises of an indoor and an outdoor unit. The indoor slim evaporator is designed exclusively for indoor floor, wall or ceiling installations while the external condenser should be installed outside while still away from flood water or snow line.
- Rating: This unit must be only connected to a 220-240 V / 50 Hz earthed power source.
- Installation must be in accordance with the regulations of the country where it is used.
- European Union regulations requires for an F-Gas trained engineer to handle any operation where non-qualified intervention could cause fluorinated gas escape. A commissioning certificate must be issued with any installation.
- This air conditioner contains R32 which is a safe efficient refrigerant which has a lower environmental burden than traditional refrigerants.
- The refrigerant used in this air conditioner is an environmentally friendly hydrocarbon R32, which has a very low Global Warming Potential compared to traditional refrigerants.
- R32 is classed as slightly flammable and as such naked flames and sources of ignition should be kept a safe distance from the unit.
- If you are in any doubt about the suitability of your electrical supply have it checked and, if necessary, modified by a qualified electrician.
- This air conditioner has been tested and is safe to use. However, as with any electrical appliance - use it with care.
- Disconnect the power before dismantling, assembling or cleaning.
- Avoid touching any moving parts within the appliance.
- Never insert fingers, pencils or any other objects through the guard
- This appliance is not intended for use by persons (including children) with reduced physical, sensory or mental capabilities. It is also not intended for use by those with a lack of experience and knowledge, unless they have been given supervision or instruction concerning the use of the appliance by a person responsible for their safety. Do not leave children unsupervised with this appliance.
- Do not clean the unit by spraying it or immersing it in water.
- Never connect the unit to an electrical outlet using an extension cord. Both the indoor and outdoor units must be hardwired by a qualified electrician.
- Never operate this appliance if the cord is damaged. Ensure the power cord is not stretched or exposed to sharp objects / edges.
- A damaged supply cord should be replaced by the manufacturer or a qualified electrician in order to avoid a hazard.
- Any service other than regular cleaning or filter replacement should be performed by an authorized service representative or a qualified air conditioning engineer. Failure to comply could result in a voided warranty.
- Do not use the appliance for any purpose other than its intended use.
- The outdoor part of the air conditioner unit must always be stored and transported upright, otherwise irreparable damage may be caused to the compressor; if in doubt we suggest waiting at least 24 hours before starting the unit.
- Avoid restarting the air conditioner unless 3 minutes have passed since being turned off. This prevents damage to the compressor.
- Never use the mains as a switch to start and turn off the air conditioning unit. Use the provided ON/OFF button located on the remote control.
- Always place the unit on a dry and stable surface. Install the outdoor unit on a wall with wall-mounted brackets or fix on floor slab with special floor mounting slab or brackets.
- The indoor unit should not be installed in laundry or wet rooms.

## Energy Saving and Unit Safety Protection Tips

- Do not cover or restrict the airflow from the outlet or inlet grills both on the indoor and outdoor units.
- For maximum performance, the minimum distance from a wall or objects should be 50cm.
- Keep the filters clean. Under normal conditions, filters should only need cleaning once every four weeks (approximately). Since the filters remove airborne particles, more frequent cleaning may be necessary, depending on the air quality.
- For the initial startup set the fan speed to maximum and the thermostat to 4-5 degrees lower than the current temperature. After, set the fan switch to low and set the thermostat to your desired setting.
- To protect the unit we recommend not using the cooling function when the ambient indoor temperature is higher than 35°C.
- To protect the unit we recommend not using the heating function when the indoor ambient temperature is lower than 7°C.
- Note the manufacturer operating temperature ranges at the end of this user manual.

## PRODUCT DESCRIPTION

### INDOOR UNIT - CEILING INSTALL

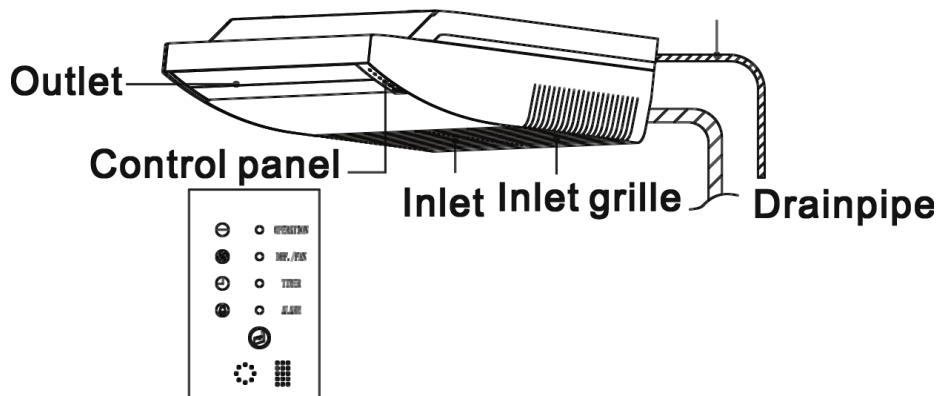

### FLOOR / WALL MOUNTED

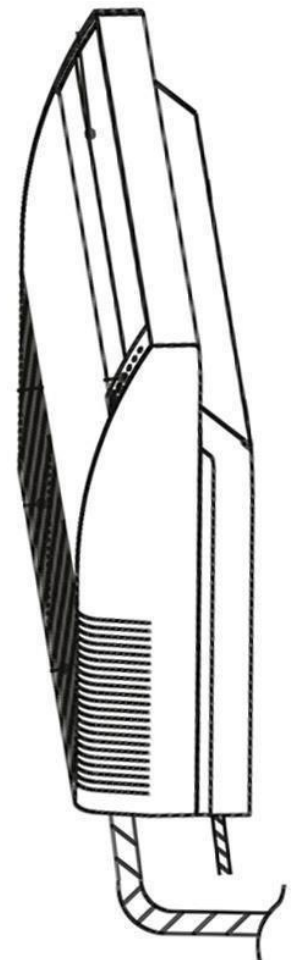

### OUTDOOR UNIT

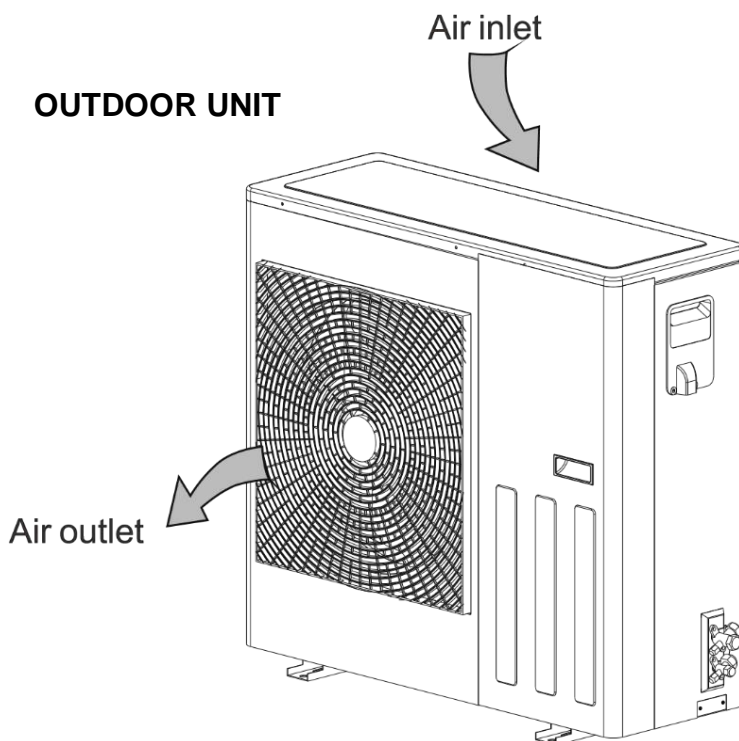

## HOW AIR SPLIT CONDITIONERS WORK

### COOLING MODE

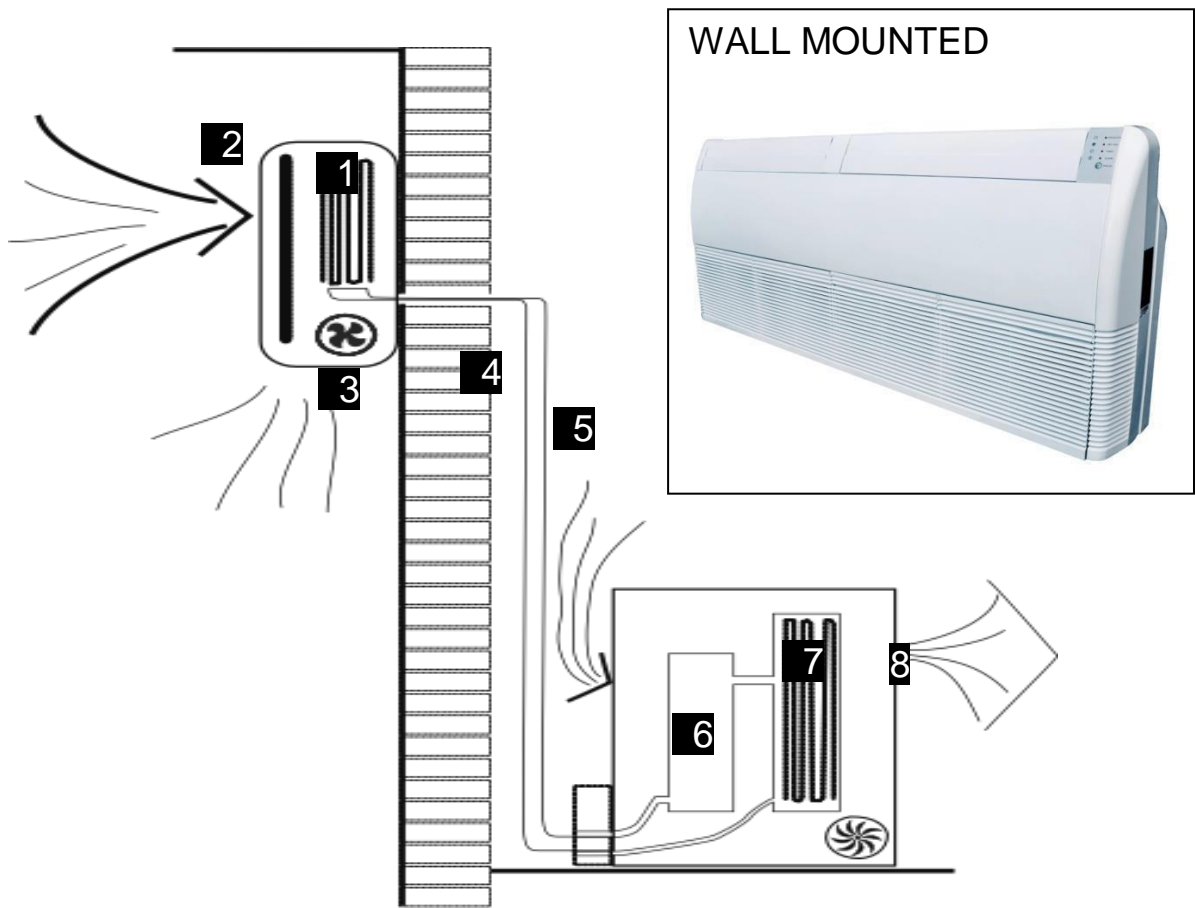

The compressor (6) in the external unit compresses the refrigerant into a high-temperature, high-pressure gas. When this gas flows along the cooling fins of the condenser (7), heat is exuded and the gas condenses into a liquid, which is then led to the evaporator (1) in the indoor unit. The liquid expands into a gas at a low temperature and low pressure. This gas absorbs the warmth of the air in the room, and a fan (3) draws the air through the filter and over the evaporator (1), blowing the cooled air back into the room. The heat is moved to the compressor along with the gas. A fan (8) draws air over the condenser and blows the warm air away.

- |               |                  |                   |
|---------------|------------------|-------------------|
| 1. Evaporator | 2. Filter        | 3. Evaporator Fan |
| 4. Gas Line   | 5. Liquid line   | 6. Compressor     |
| 7. Condenser  | 8. Condenser Fan |                   |

### HEAT PUMP MODE

The system operates in reverse: the condenser works as an evaporator, the evaporator as a condenser: warm air is blown into the room. It is ideal as a maintenance heating when outside temperature is not too low and when the indoor temperature is more than 7°C.

### DEHUMIDIFYING

As with cooling, the moisture in the air condenses on the cold evaporator at room temperature acting as a powerful dehumidifier.

## ALTERNATIVE WAYS TO MOUNT

### CEILING MOUNTED

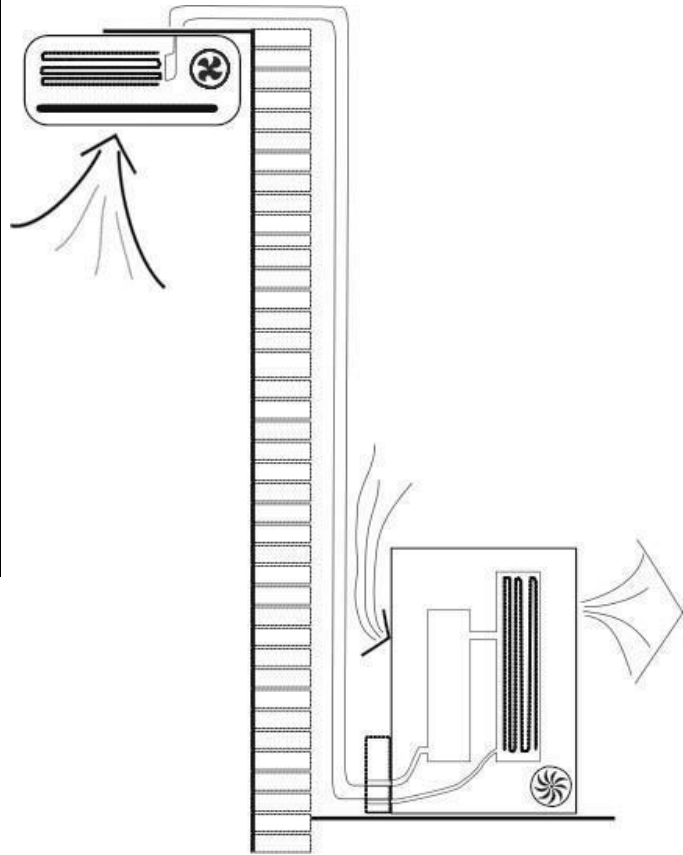

### FLOOR MOUNTED

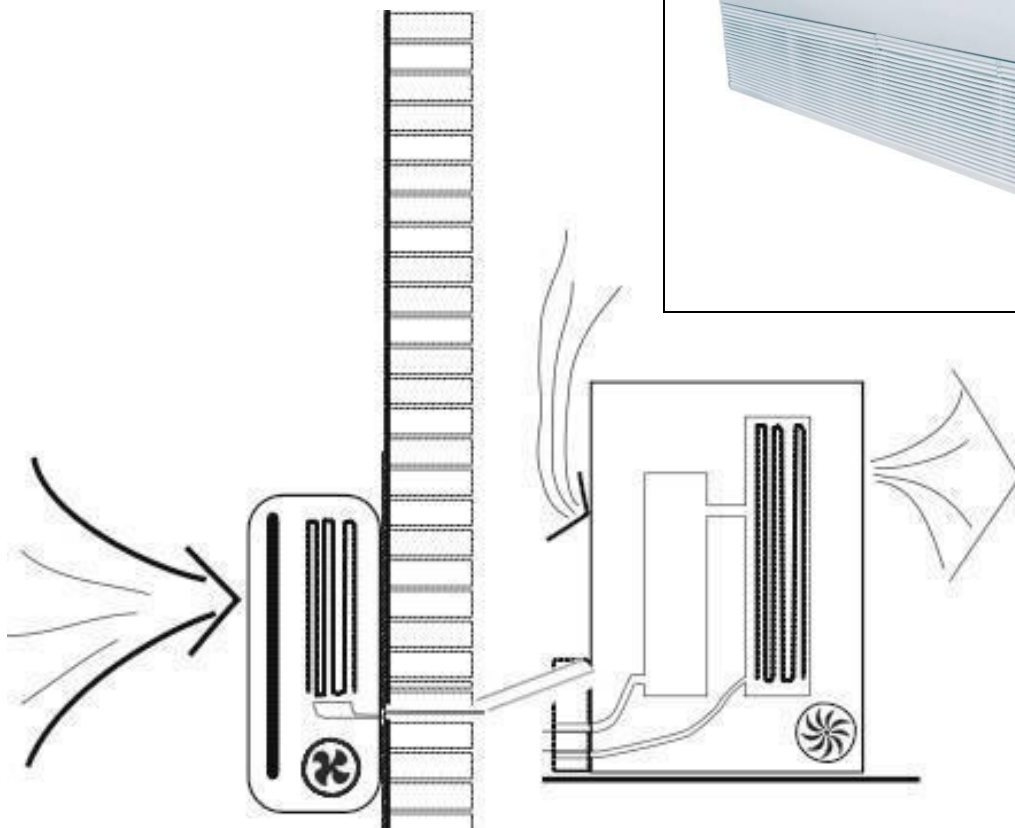

## DISPLAY PANEL

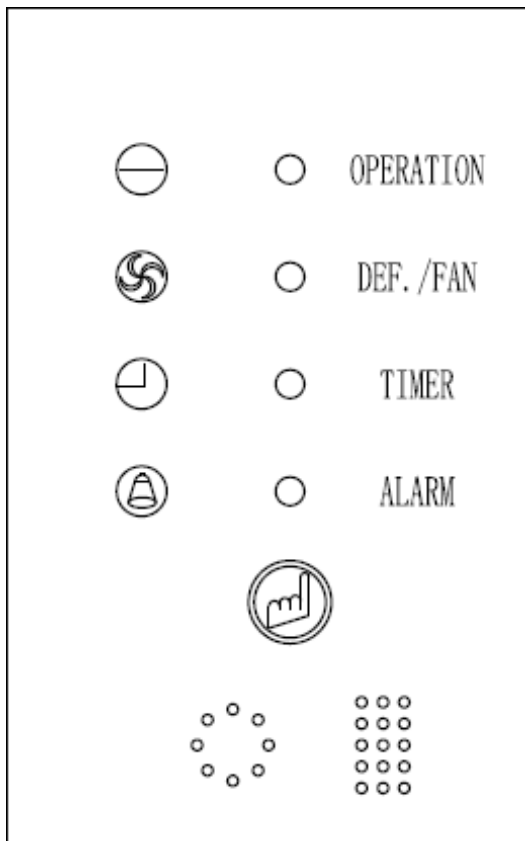
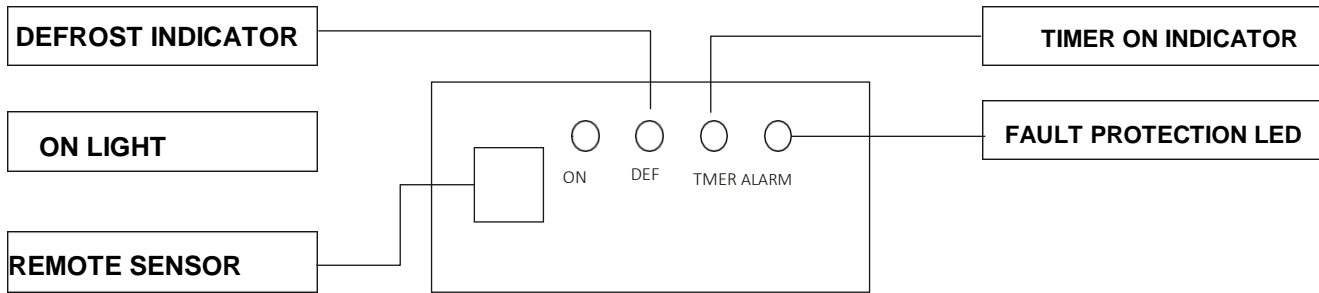

The air conditioner has a simple to read display panel.

ON (GREEN)	Shows the unit is switched on and working
DEF (RED)	Defrost protection activated. In cold temperatures the unit will enter defrost mode to prevent compressor damage and the compressor will heat for a while
TIMER (YELLOW)	Indicates the timer is active
PROTECTION (RED)	Fault protection mode may be activated to protect the compressor if abnormal operation is detected.



## REMOTE CONTROL DIAGRAM

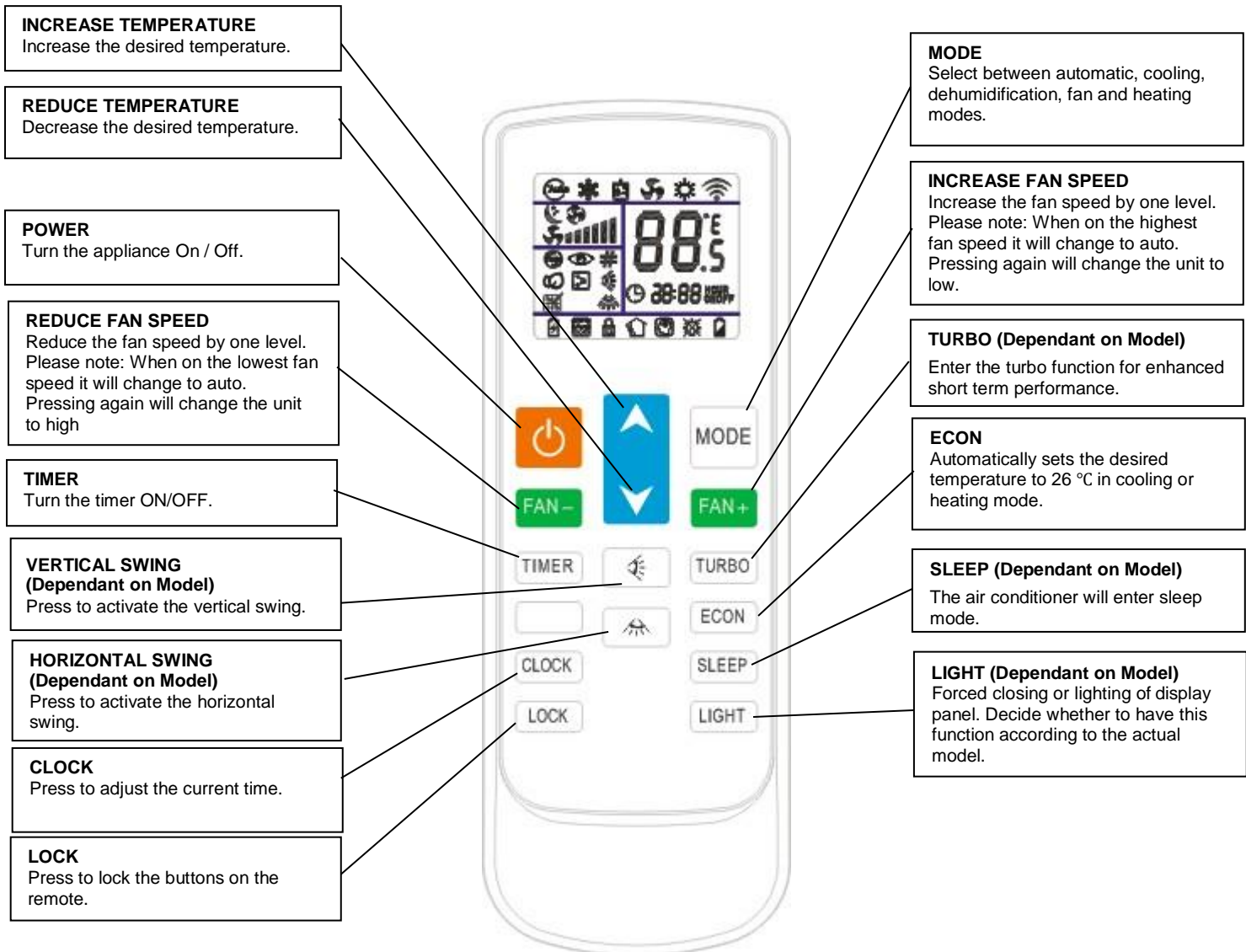

### NOTICES FOR REMOTE CONTROL:

1. Do not place the remote control near high temperature heat sources.
2. Do not leave the remote control exposed to the direct sunshine.
3. Be careful not to drop the remote as this may lead to damage.
4. There must be no barrier between the signal receiver and remote control as this may affect communication between them.
5. Do not allow the remote control to be splashed or immersed in water.
6. Do not place heavy items on top of the remote control.



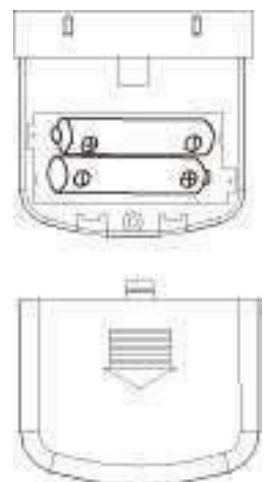





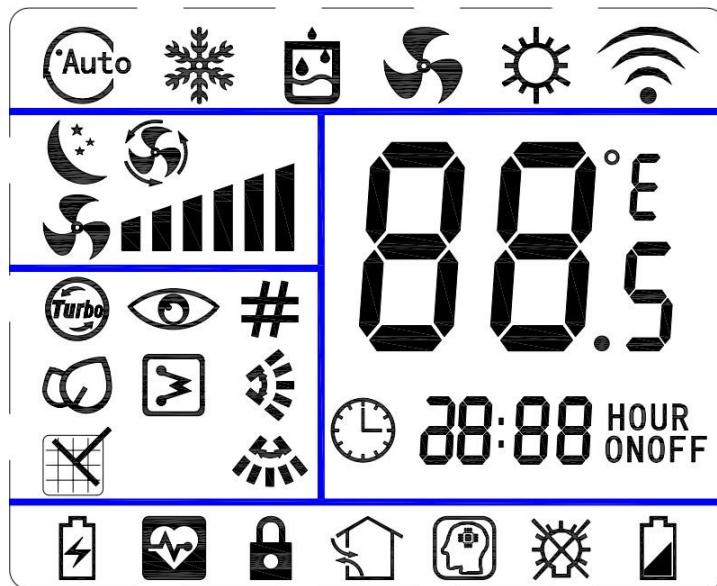











Note: In case of failure of the remote control, please remove the back cover and replace the batteries, before repeating the operation; if the failure still exists, please run the air conditioner using the emergency operation method, and contact the manufacturer or retailer.





## REMOTE CONTROL DISPLAY



MODES		OTHER ICONS	
	AUTO MODE		CLOCK
	COOLING MODE		SLEEP FUNCTION
	DEHUMIDIFIER MODE		TURBO FUNCTION
	FAN MODE		ECON FUNCTION
	HEATING MODE		CLEANING FUNCTION
TEMPERATURE DISPLAY			REMOTE LOCKED
	CURRENT TEMPERATURE Ranges between 16 - 32°C		BATTERY LOW
FAN SPEED			AUTO CONFIG
	LENGTH OF BAR INDICATES FAN SPEED		POWER SAVING MODE
	AUTOMATIC FAN SPEED		HEALTH MODE
TIMER			INTELLEAGENT MODE
HOUR ON	ON TIMER		BACKLIGHT OFF
HOUR OFF	OFF TIMER		ADDRESS

## **REMOTE CONTROL FUNCTIONS**

### **POWER**

This button will turn the air conditioner On and Off.

1. When first powered on, air conditioner will start with the default settings:
  - Desired temperature 25°C
  - Automatic mode and Automatic fan speed.
  - Vertical and Horizontal Swing.
  - TURBO, Sleep, Timer and lock off.
2. When powered on subsequently the unit will continue with the previously used settings but sleep, TURBO, ECON and timer functions will be cancelled if previously activated.

### **MODE**

1. Press this button to change between Automatic, cooling, dehumidify, fan and heating modes.
2. The dehumidification mode is set with a desired temperature of 25°C and the temperature cannot be adjusted.

### **REDUCE TEMPERATURE ▼**

1. When pressing this button, the desired temperature will be reduced by 1°C. When pressing this button in dehumidification and fan modes, the desired temperature will not be adjusted.
2. After the clock button has been pressed (The clock icon will flash), this button is used to set the time.

### **INCREASE TEMPERATURE ▲**

1. When pressing this button, the desired temperature will be increased by 1°C. When pressing this button in dehumidification and fan modes, the desired temperature will not be adjusted.
2. After the clock button has been pressed (The clock icon will flash), this button is used to set the time.

### **VERTICAL SWING - EXTERNAL FLAPS (DEPENDANT ON MODEL)**

1. Press this button to change the vertical swing between fixed position and swing operation.
2. Press this button in dehumidify mode to close the external flaps.

### **HORIZONTAL SWING - INTERNAL FLAPS (DEPENDANT ON MODEL)**

1. Press this button to change the horizontal swing between fixed position and swing operation.
2. Press this button in dehumidify mode to close the internal flaps.

### **REDUCE FAN SPEED**

1. Press this button to reduce the fan speed. When going below low, the unit will enter Automatic mode. When pressed again the fan speed will be set to high.
2. In dehumidify mode, the fan speed is fixed to low and is not adjustable.

### **INCREASE FAN SPEED**

1. Press this button to increase the fan speed. When going above high, the unit will enter Automatic mode. When pressed again the fan speed will be set to low.
2. In dehumidify mode, the fan speed is fixed to low and is not adjustable.

## **TIMER**

The timer can be used as a start timer or a shutdown timer and can be set between 1 hour and 24 hours in 1 hour increments. This is a one use timer, and multiple timers cannot be combined.

### **START TIMER**

1. With the air conditioner turned off, press the timer button, before using the ▲ and ▼ buttons to set in how many hours you would like the unit to start.
2. The unit will operate with the settings used before the appliance was turned off.

### **SHUTDOWN TIMER**

1. With the air conditioner running with the desired setting, press the timer button, before using the ▲ and ▼ buttons to set in how many hours you would like the unit to turn off.

## **TURBO (dependant on model)**

1. The TURBO button will not work in Automatic, Dehumidify or fan modes.
2. Press this button in cooling or heating modes to turn the TURBO function on or off.
3. When in the TURBO mode the fan speed will not be displayed.
4. Switching modes or pressing the sleep button will turn off TURBO mode.

## **ECON**

1. The ECON button will not work in automatic, dehumidify or fan modes.
2. Press this button in cooling or heating modes to turn on ECON mode.
3. When in ECON mode, the desired temperature is set to 26°C.
4. When ECON mode is turned off the desired temperature will return to the value before the button was pressed.
5. Switching between modes will turn off ECON mode.

## **SLEEP**

1. Sleep mode can be activated in all modes apart from Fan mode.
2. Switching mode will cancel the sleep function.
3. When sleep mode is activated the fan speed will automatically be set to low, but can still be increased if necessary (except in dehumidification mode).

## **LIGHT (DEPENDANT ON MODEL)**

1. Press to turn the backlight on and off.

## **CLOCK**

1. This button is used to set the clock. Press to adjust the hour value, the hour figure on the LCD will flash. Use the ▲ and ▼ buttons to adjust.
2. When the hour is set, press the clock button again to adjust the minute value, the minute figure on the LCD will flash. Use the ▲ and ▼ buttons to adjust.
3. After adjusting, press the clock button again to confirm the time set. If no buttons are pressed for 3 seconds, the changes will be cancelled and the remote will return to normal operation.

## **LOCK**

1. Press the Lock button to lock the buttons on the remote control.
2. When the remote is locked, the only button still active is the lock button

## **BUTTON COMBINATION: FAN - + FAN +**

Will change the remote from showing 3 fan speeds to 6 fan speeds. As the air conditioners only supports 3 speeds, 1/2 is Low speed, 3/4 is Medium speed, and 5/6 is high speed.

## **IMPORTANT INFORMATION**

### **AUTO RESTART**

The air conditioner will automatically restart when electricity is restored after a power cut. If in doubt, check the settings.

### **RANGE OF INTERNAL THERMOSTAT**

The internal thermostat can be set at a desired temperature between 16 and 32°C. Note that whether the desired value is achieved depends on the room size, temperature and insulation of the room.

### **RANGE OF HEAT PUMP FUNCTION**

The heat function can be used when the external ambient temperature is above -15°C. The performance of the heat pump will degrade with lowering external temperatures. Please note the performance will reduce when the outdoor temperature drops below 5°C.

### **CAPACITY**

The required cooling or heating capacity depends greatly on the location and/or use of the room where the air conditioner is installed. Strong sunlight and the presence of people, lights or equipment creates an additional heat load. Normal living spaces require about 350 Btu per square metre of floor surface. In strong sunlight or if other sources of heat are present, this may be as much as 1200 Btu per sqm.

Tip: On warm days, let the air conditioner cool the room as much as possible during the night and keep the temperature constant from night to daytime.

## FILTERS

Turn off the appliance from the consumer unit before attempting to service the filters. Never attempt servicing the unit while the power is on. If the unit is ceiling mounted, please ensure enough space is left to service the filters

Identify the filters and remove them as per the procedure bellow



Find the groove on the panel and pull the filter out

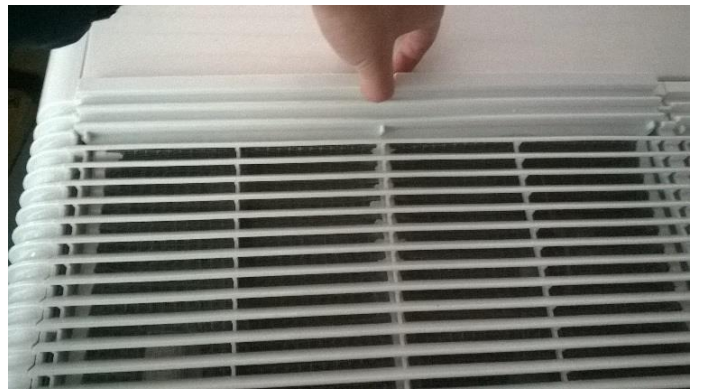

When removing the filter please make sure you do it from middle or use both hands ensuring it is pulled with equal force. Failure to do this may damage the filter.



Use a vacuum cleaner to remove dirt. If the dust filter is very dirty, it may be washed in lukewarm water with a very small amount of neutral detergent. Rinse well and allow to dry completely (not in direct sunlight or near a source of heat).

Reverse the filter removal procedure and push back the clean filter. Keep the filter parallel with panel.



Restore the power from the consumer unit and turn the air conditioner on.

**INDOOR UNIT:** While the unit is disconnected from power dust regularly with a dry cloth or slightly damp paper towel. Never use chemicals or solvents. Never spray a liquid in or over the appliance.

**OUTDOOR UNIT:** While the unit is disconnected from power, remove dirt and keep the air intake and exhaust openings free of debris, etc. Cleaning with chemicals may cause damage. Use professional installers to service the fan or the other parts.

## START OF SEASON

If the air conditioner is to be used again after an extended period:

- Check that the air intake and exhaust openings of the indoor and outdoor units are not blocked. Remove all dirt and debris.
- Check that filter is installed and is clean.
- Check that the condensation outlet drains properly and there is no dirt or organic blockage (otherwise leakage may occur)
- Install 2 AAA batteries in the remote control.
- Turn the appliance on, set the time and desired setting.

## END OF SEASON

If the air conditioner is not going to be used for an extended period:

- Set in fan mode on a slightly warm day so that the inside of the appliance dries out.
- Switch off the power at the fuse box
- Remove the batteries from the remote control.
- Clean the filters.

## INSTALLATION GUIDE

### SAFETY

- Only qualified personnel should install this appliance.
- This installation manual is intended for use by individuals possessing adequate backgrounds and qualifications in electrical, electronic, refrigerant and mechanical fields.
- Any attempt to install or repair the appliance may result in personal injury and property damage.
- The manufacturer or seller cannot be responsible for the interpretation of this information, nor can it assume any liability in connection with its use.
- The units are designed for permanent installation.
- The equipment is designed for domestic or office use and we are not making any endorsements for use in industrial or maritime environment.
- Do not place near sources of heat, vapours, industrial machine oil or other flammable gases.
- High-frequency waves generated by radio equipment, welders and medical equipment will interfere with the normal operation of the unit.
- Install this device only when it complies with local/national legislation, ordinances and standards.
- Check the mains voltage and frequency. This unit is only suitable for earthed electrical supply, connection voltage 230V~/ 50 Hz.
- The fuse used should be 1.5 – 3 times the maximum power of the unit.
- The information, specifications and parameter are subject to change due to technical modifications or improvement without any prior notice. The accurate specifications are presented on the nameplate label.
- Please read this installation manual completely before installing the product.
- When the power cord is damaged, replacement work shall be performed by authorised personnel only.
- Installation work must be performed in accordance with all European, national and / or local directives and standards and must be done by authorised personnel only.
- Always make sure to wear the correct personal safety protections such as protective eyewear, gloves, ear protection etc.
- This air conditioner contains a refrigerant and can be classified as pressurized equipment. Therefore always contact an authorised air conditioning engineer for installation and maintenance of the air conditioner.
- The air conditioner must be inspected and serviced on an annual basis by an authorised air conditioning engineer.



**INDOOR UNIT POSITION AND SPACING**

The air inlet and outlet vent should be away from any obstruction, ensuring that there is good airflow through the whole air- conditioned space. Select a position where the condensing water can be easily drained out, and the indoor unit can be easily connected to outdoor unit.

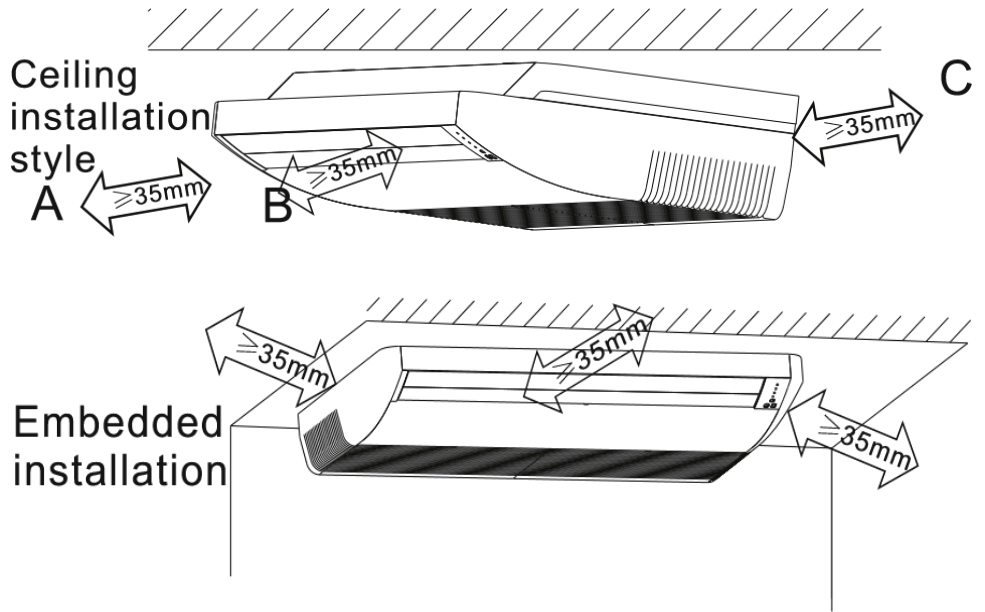

The wall or ceiling where the unit is fixed should be strong enough to withstand the full weight and vibration of the unit. You can use specialised ceiling mounting brackets (not supplied) if installed in the ceiling void. The unit should be accessible for service and maintenance. The air conditioner must not be installed in a wet environment such as a bathroom, shower or swimming pool etc.

Make sure that there is a minimum of 35 mm clearance in all directions A, B, C.

When outdoor unit is installed higher than indoor unit, in order to avoid water getting into the room from the connecting pipe, you should make a curved bend (the curve face down) at the connecting pipe before it gets through the wall to the indoor room, make sure the vertex is outdoor.

**When the outdoor unit is installed higher than indoor unit, in order to avoid water leakage please ensure the drain pipe is using the gravity fall straight down or use an inline uplift pump. If there is more than 5 meters differential a loop should be used.**

**When drilling through the wall ensure a 2-5 degrees angle, as shown in the picture bellow**

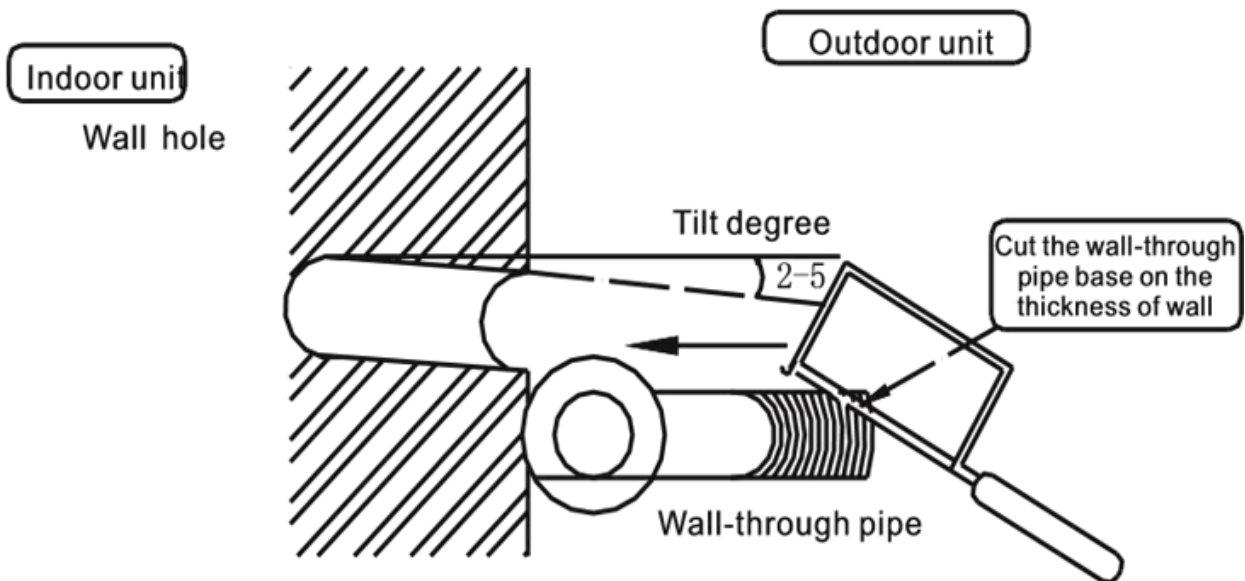

## INSTALL DIMENSION REQUIREMENTS FOR OUTDOOR UNIT

Position	Minimum Clearance
Left	50 cm
Right	50 cm
Back	30-50 cm
Front	200 cm

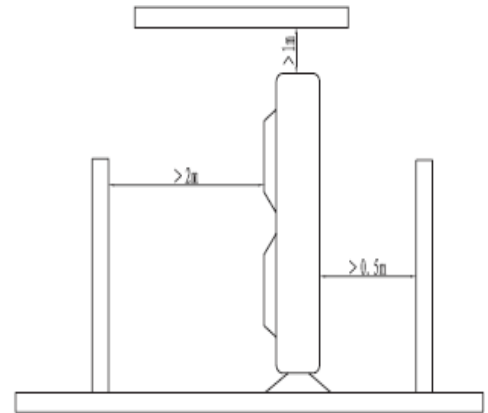
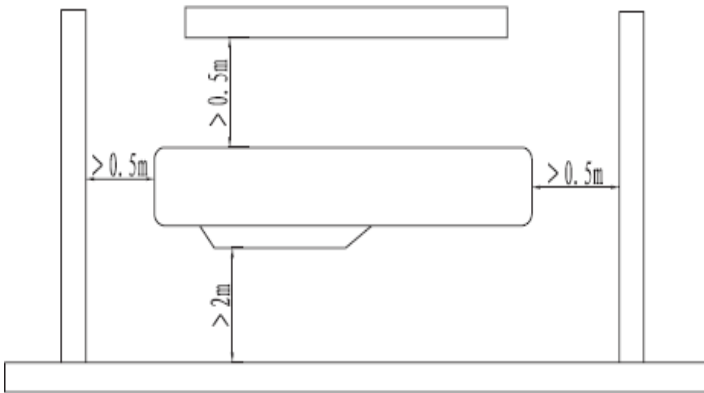

### OUTDOOR UNIT POSITION

A convenient position, dry and well ventilated, outside of direct sunlight or strong winds, which is not on a flood line and where noise and airflow does not cause interference or inconvenience. Select a location where there are no obstructions to the inlet and outlet vents. The location should be able to withstand the full weight and vibration of the outdoor unit and permit safe installation.

Make sure that the outdoor unit installation is made in respect to installation dimension diagram with easy maintenance access. Select a place where it is out of reach of children. Do not block utilities access or fire escapes.

The external unit must be lifted and put in place by two people or by specialised equipment. Please follow the bellow guidance for clearance when installing the outdoor unit.

Constricting the airflow can prevent the unit from operating correctly and may result in damage to the appliance.

### NOTES:

1. Only use correct power voltage making sure the correct sized power cables are used
2. The appliance shall be installed in accordance with standard wiring regulations by qualified personnel
3. Only replace fuses according to their printed rating or corresponding pcb boards.

## TOOLS RECOMMENDED FOR INSTALLATION



Electric Drill



Hammer



Screwdrivers



Tape Measure



Core Hole Cutter



Spirit Level



Number 14 (7mm)  
Masonry Drill

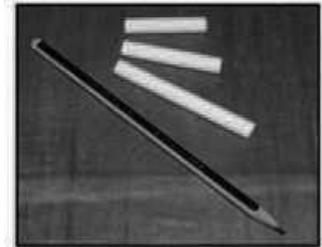

Pencil and Chalk



1.5 inch number 10  
screws



Small Stepladder



7mm Wall Plugs



Protective Glasses  
and Mask



Pipe and Cable  
Detector

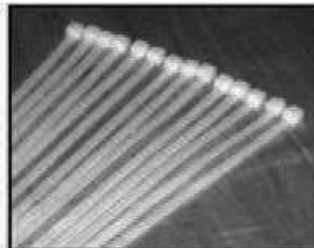

4 inch Plastic Ties



2 Inch Pipe Clips



Circuit Breaker



Garden Gloves



Dust Sheets



Foam Filler



Silicone Sealant  
and gun

## INSTALLING THE INDOOR UNIT

- Select the location of the internal unit, determining the fixing direction and where the pipework will go.
- Check that the wall where the pipework will be placed through is clear of any wiring or other internal pipework or structures, before drilling a 90mm diameter hole (slanted slightly downwards).

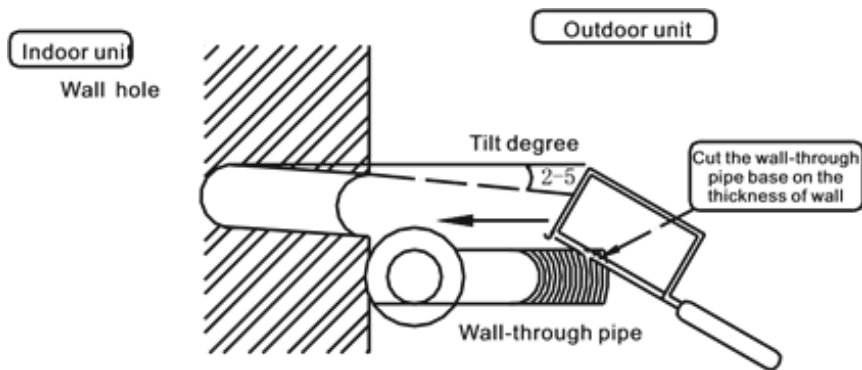

- Cut the through wall pipe to the desired length and then place it in the drilled hole.

## CEILING MOUNTING

- The mounting surface should be solid brick, concrete or other equivalent strength structure with sufficient loading capacity. Failing this you must take reinforcing, bracing and vibration reduction measures.
- Install the 4, 10mm lifting bolts in the ceiling, noting the correct procedure for the type of ceiling being fitted to.
- Lift the indoor unit into place using the necessary lifting equipment.
- Ensure the unit is perfectly horizontal as failure to do so may cause water leakage during operation..

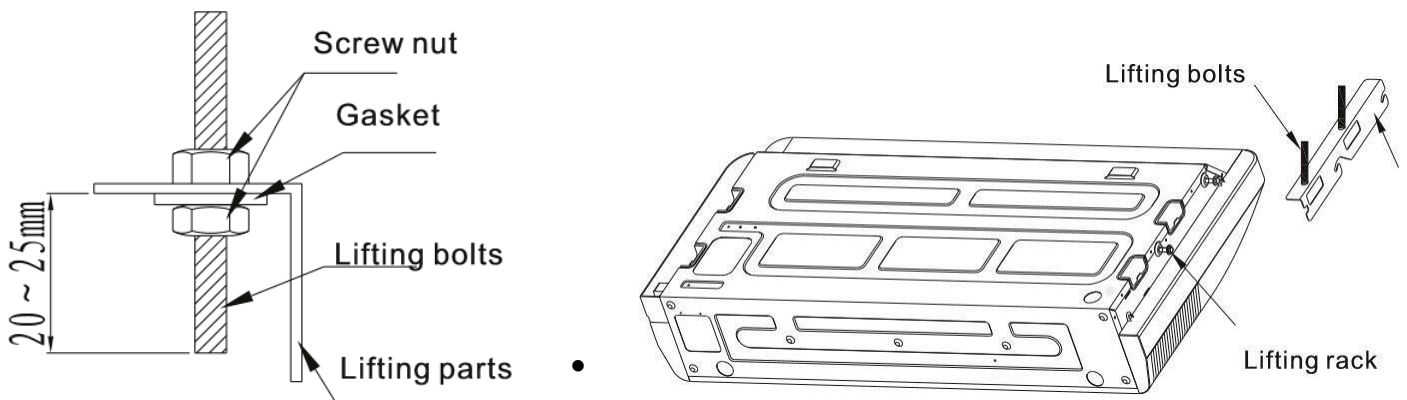

- Once the indoor unit is hung in place, the wiring and pipework can be connected. If space is tight you may need to fit the copper pipes, drain pipes, control and electrical wires before you permanently hang the indoor unit

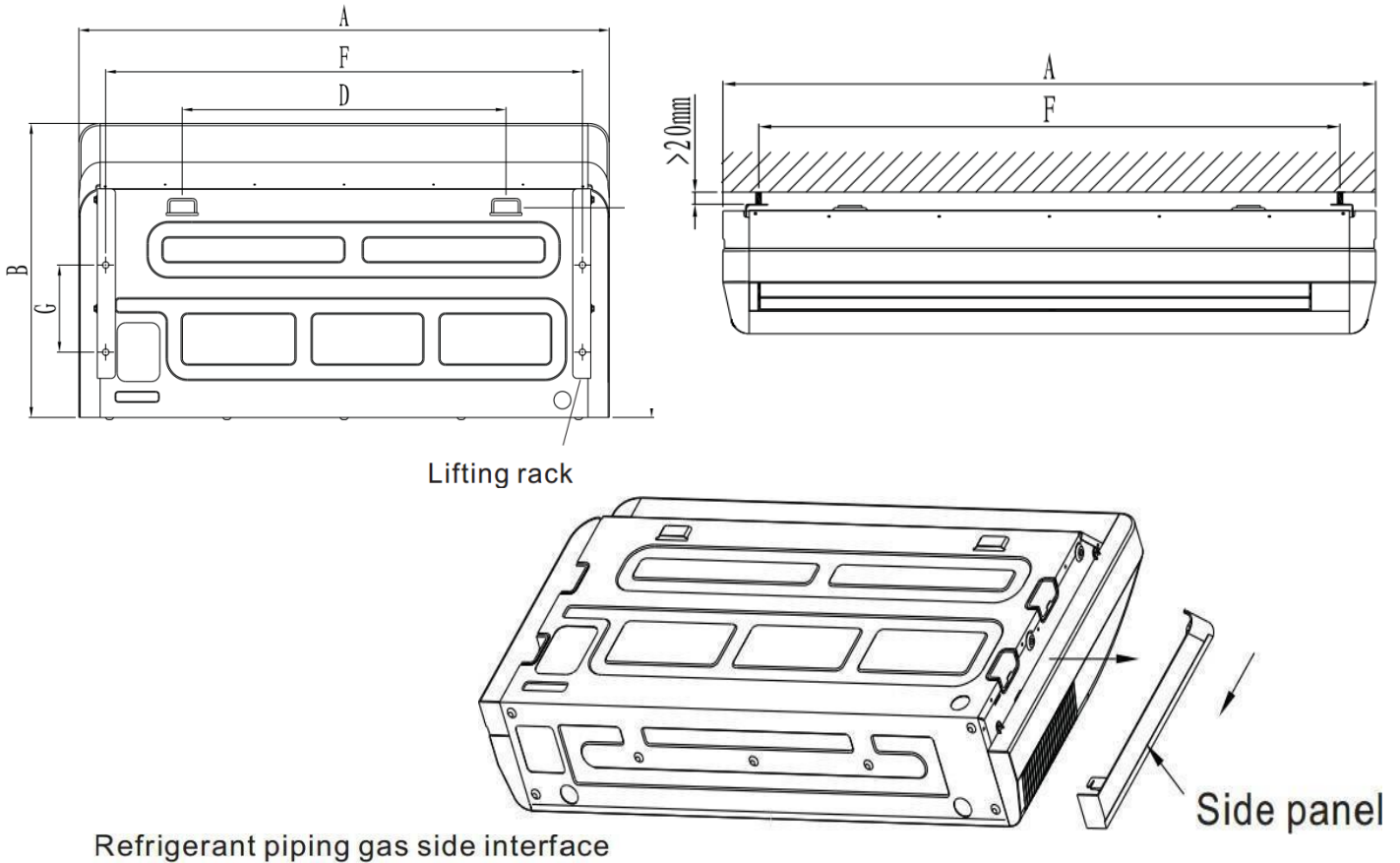

The installation steps for embedded style are basically the same with the hanging style, but remove the left and right panels of the indoor unit and then embed half of the unit body into the ceiling showing up only the back panel and top panel.

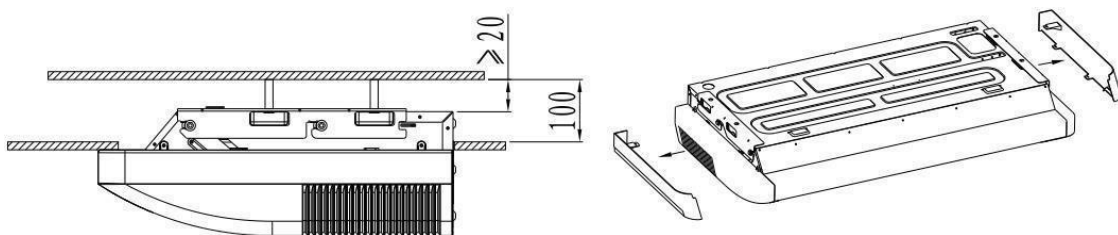

## ALTERNATIVE CEILING MOUNTING METHOD USING LIFTING BOLTS

Matching the structure of the ceiling, set the thread pitch based on the size of this unit as bellow

### WOODEN STRUCTURES

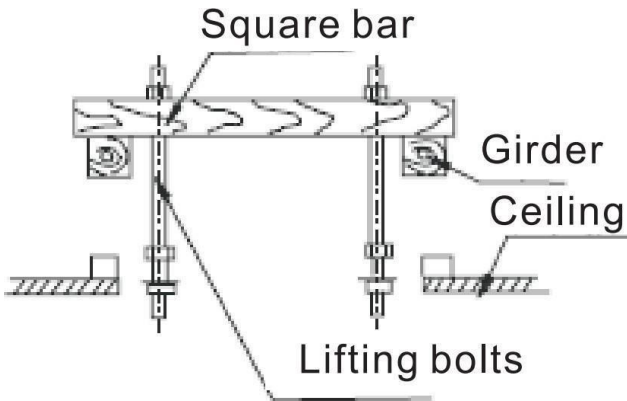

### STEEL SKELETON STRUCTURES

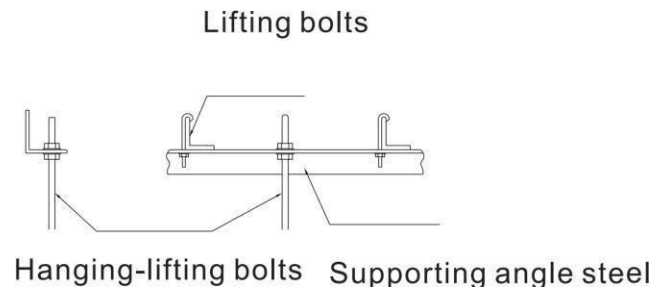

Place the square bar on the girders and install the lifting bolts. Set directly on the supporting steel

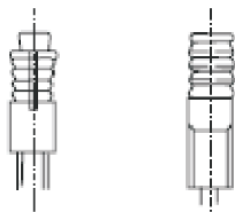

Knife-type inserts

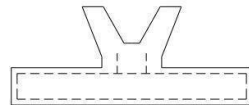

Sliding inserts

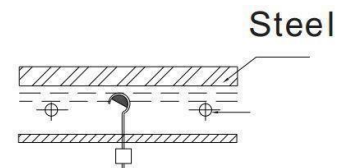

Embedded bolt (hanging-buried bolt for pipe)

Different type of bolts or inserts can be also used.



## FLOOR / WALL MOUNTING

For floor or wall mounting use embedded or expandable bolts strong enough for the type of wall. Install the unit with the control panel facing up similar to a radiator and make sure it is correctly aligned and level.

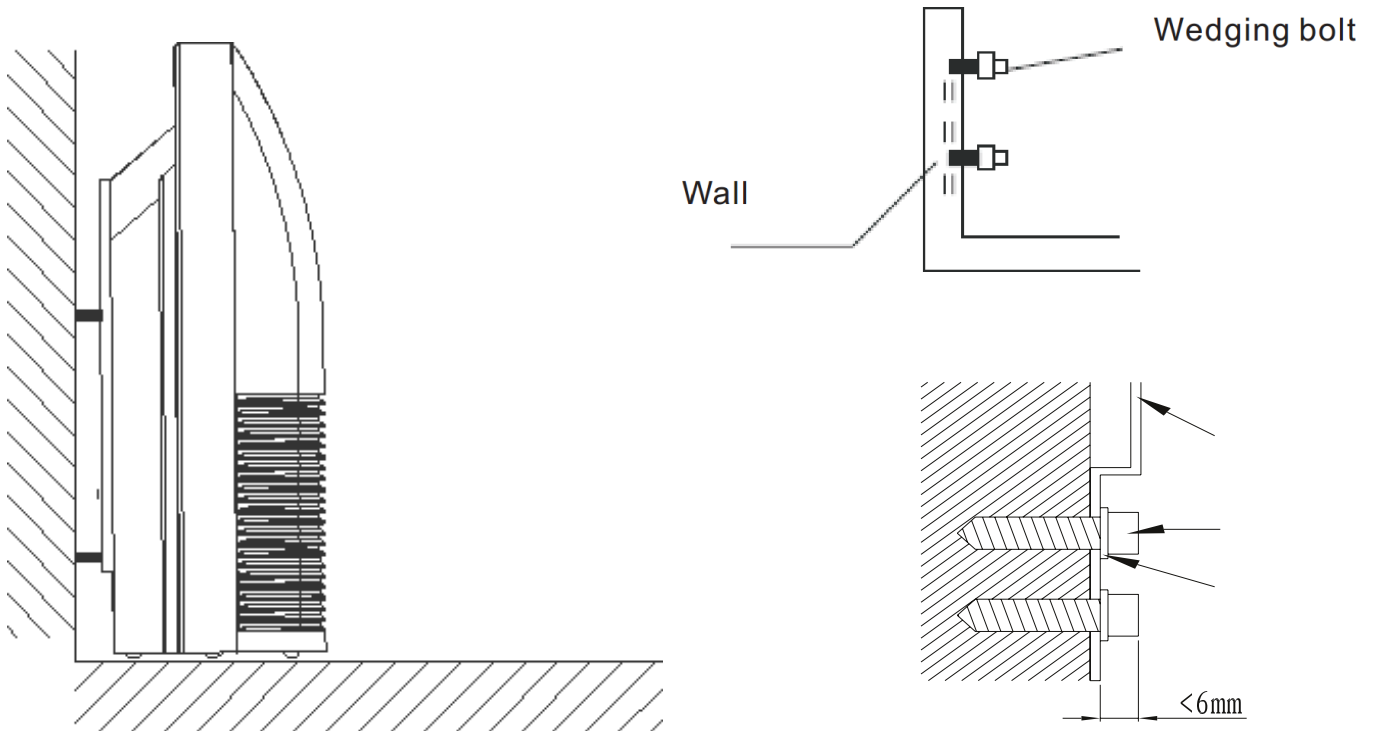

Make sure that the drain pipe is underneath the pipelines. (When the drain pipe passes the room interior, some condensed water might occur to its surfaces if the humidity is very high). Tidy up the copper pipes, electrical cables and water drains and pass them through the piping wall hole drilled before.

### Notes:

1. Either the indoor unit or the outdoor unit can be higher, but the height difference must comply with a max. 5 metres level difference.
2. Try to reduce the bending of the pipes as much as possible so as to avoid possible negative impacts upon the performances of the unit.
3. Unit can be installed both vertical (floor or wall mounting – fig1) or horizontal (ceiling or embedded mounting – fig2). Run the pipes on the back of the indoor unit according to the install type

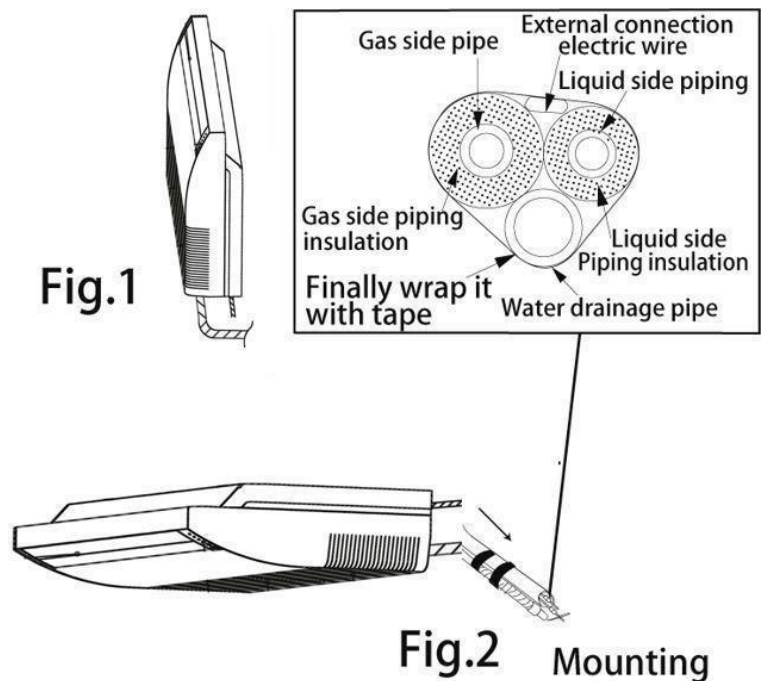



## INSTALLATION OF THE OUTDOOR UNIT

- Try to move the product to the installation location in its original packaging.
- As the gravity centre of the unit is not at the installation centre, special caution should be taken when using hoisting cables to lift it up
- During transport, the outdoor unit must not be tilted to over 45 degrees (also do not store the unit horizontally).
- Use expansion bolts to fix the mounting supports on the wall.
- Use bolts and nuts to fix the outdoor unit firmly on the supports and keep on the same level.
- If the unit is installed on the wall or at the rooftop, the supports have to be firmly fixed so as to resist earthquake or strong wind.

Model	Pipes	Electrical cable specs		
		Outdoor power supply line(quantity, diameter, length)	Indoor power supply line (quantity, diameter, length)	Indoor/outdoor signal line (quantity, diameter, length)
eiQ-FC18K	( $\Phi 6.35 \times 0.7 + \Phi 12.7 \times 0.75$ ) $\times 5$ m	3 $\times 2.5$ mm <sup>2</sup>	/	4 $\times 2.5$ mm <sup>2</sup> $\times 6.3$ m
eiQ-FC24K	( $\Phi 9.52 \times 0.75 + \Phi 15.88 \times 0.8$ ) $\times 5$ m	3 $\times 2.5$ mm <sup>2</sup>	/	4 $\times 2.5$ mm <sup>2</sup> $\times 6.3$ m
eiQ-FC36K	( $\Phi 9.52 \times 0.75 + \Phi 15.88 \times 0.8$ ) $\times 5$ m	3 $\times 4$ mm <sup>2</sup>	/	4 $\times 2.5$ mm <sup>2</sup> $\times 6.3$ m

## DIMENSIONS FOR PARALLEL UNITS INSTALLATIONS

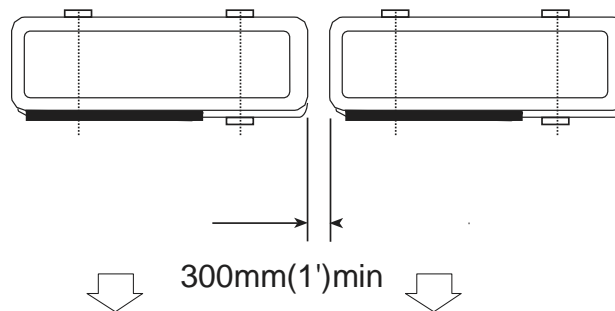

## FOOTPRINT OF THE OUTDOOR UNITS

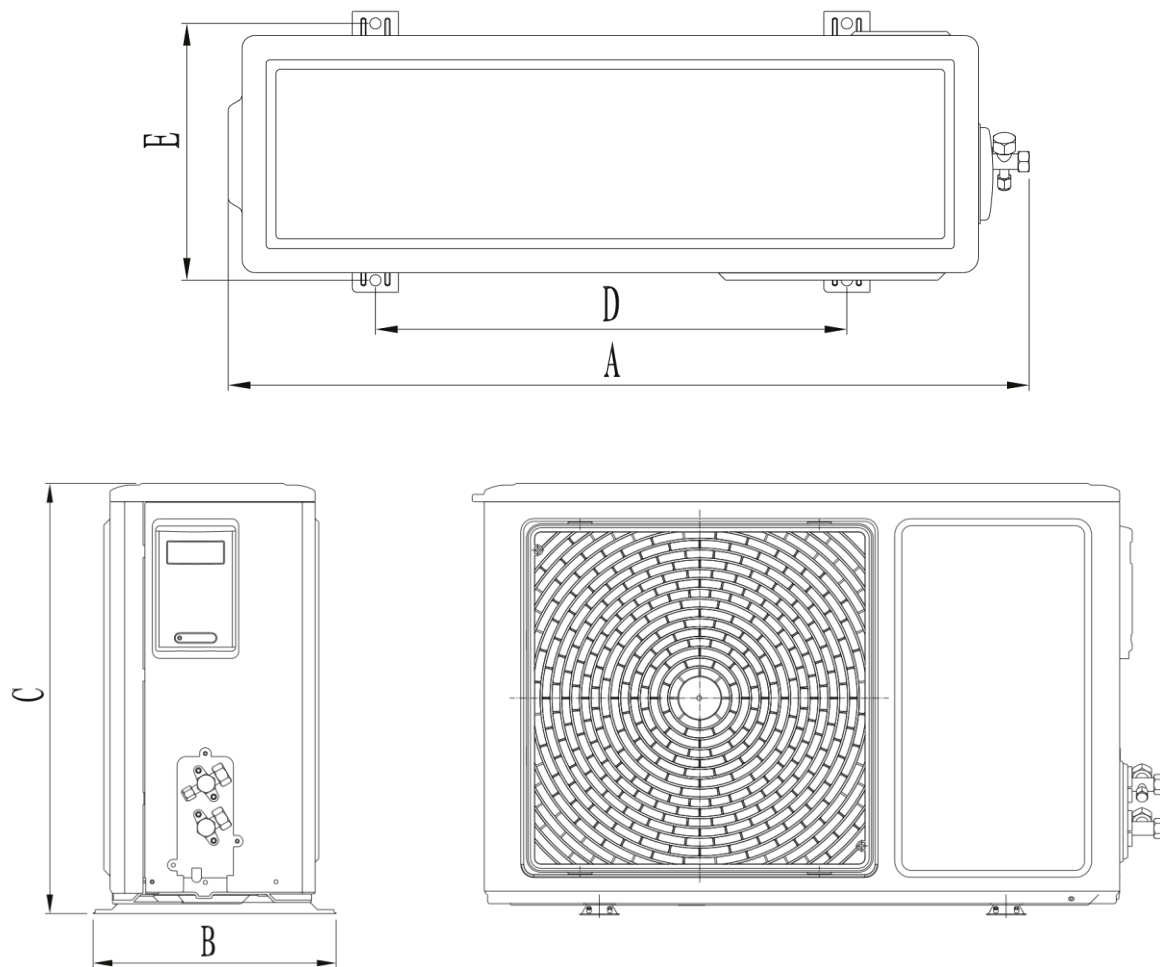

DIMENSIONS (mm)	A	B	C	D	E
Unit eiQ-FC18	925	366	700	590	340

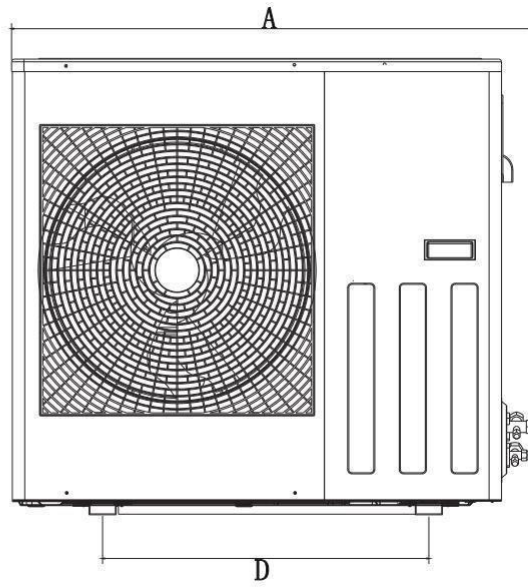
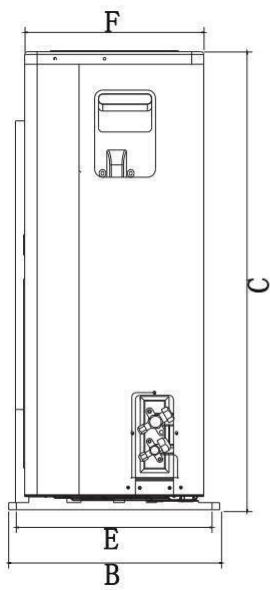

DIMENSIONS ( mm )	A	B	C	D	E	F
Unit eiQ-FC24	958	392	843	600	360	330

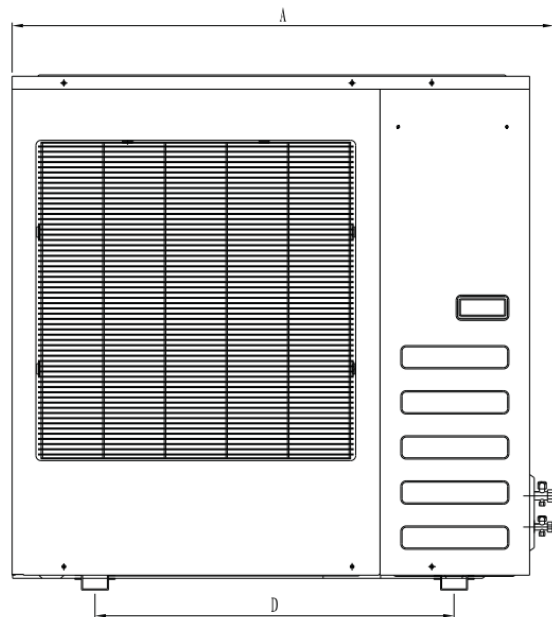
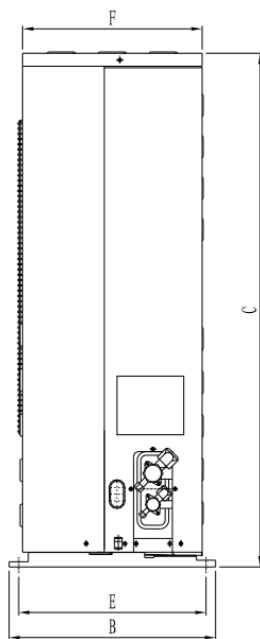

DIMENSIONS ( mm )	A	B	C	D	E	F
Unit eiQ-FC36	1030	432	788	707	389	370

## PIPELINES CONNECTION & AIR PURGING

No dust or any other particles, air or moisture should be allowed to enter the air conditioning system. Careful attention should be paid when pipeline connection for outdoor unit is made. Try to avoid repeated curves as much as possible; otherwise, damage to the copper pipes may occur. Suitable wrenches should be used when the pipeline connection is done so as to ensure appropriate torque (refer to torque table).

Excessive torque action might damage the joints while too little torque might lead to leakage.

Connecting cable

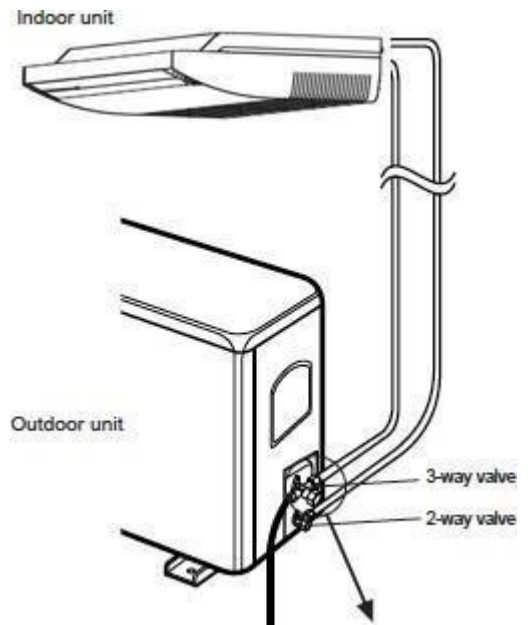
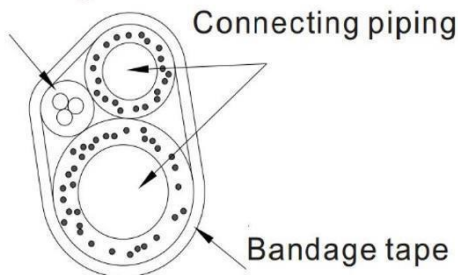

Minimum bent radius 100 mm

Peel about 10 cm - 15cm of the thermal insulation sleeve in out-pipe and in-pipe of indoor unit in preparation for pipe connections. First connect the low-pressure pipe and after this the high-pressure pipe. Press the surface of the pipe against the connector vertically, twist the connectors to the bottom of the bolt and finally tighten them with a torque wrench.

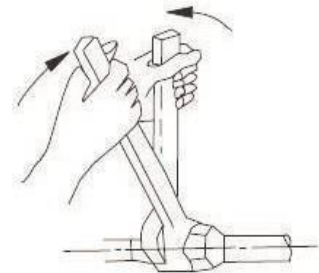

### AIR PURGING WITH VACUUM PUMP

1. Check that pipelines connection have been properly connected, remove the charging port cap, and connect the manifold gauge and the vacuum pump to the charging valve using service hoses as shown
2. Open the valve on the low-pressure side of manifold gauge, then run the vacuum pump. Vacuum the indoor unit and the connecting pipes until the pressure in them lowers to below 1.5mmHG (The operation time for vacuuming is about 10 minutes). When the desired vacuum is reached, close the valve of the low pressure of the manifold and stop the vacuum pump.
3. Disconnect the service hoses and fit the cap to the charging valve.
4. Remove the blank caps, and fully opens the spindles of the 2-way and 3-ways valves with a service valve wrench.
5. Tighten the blank caps of the 2-way and 3-ways valves, following the torque table

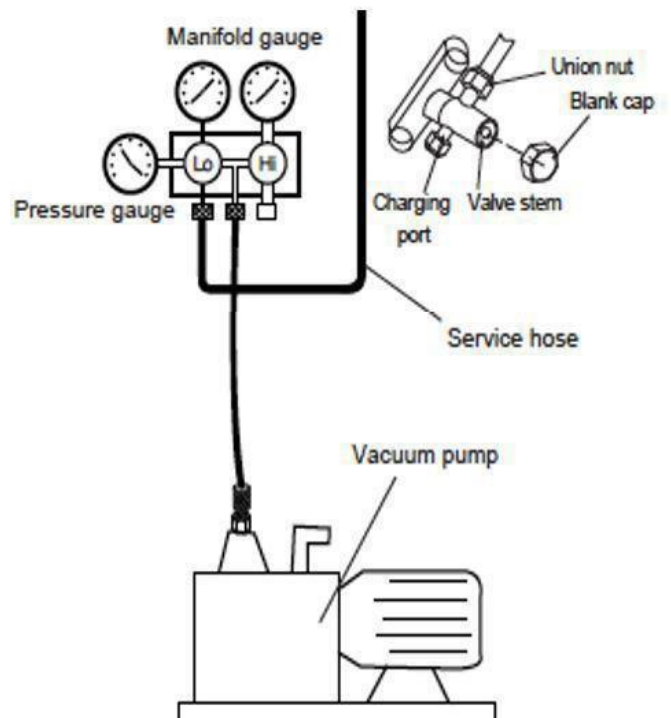

## TORQUE TO BE USED TO TIGHTEN THE CONNECTIONS

Outside diameter of the copper pipe (mm)	Tightening torque(N·cm)	Strengthened tightening torque (N·cm)
Φ6.3 or Φ6	1570(160kgf·cm)	1960(200kgf·cm)
Φ9.52 or Φ9	2940(300kgf·cm)	3430(350kgf·cm)
Φ12.7 or Φ12	4900(500kgf·cm)	5390(550kgf·cm)
Φ16	7360(750kgf·cm)	7850(800kgf·cm)
Φ19	9720(900kgf·cm)	11860(1210kgf·cm)

## ADDING REFRIGERANT

Units are pre-gassed for up to 5 meters of pipe. Refrigerant must be added if the pipework measures more than 5 metres (16'5") in length. This operation can only be performed by a professional F-Gas engineer, for the additional gas amount, see the below

Liquid pipe diameter	Additional Refrigerant	Additional Refrigerant
Φ6.3 or Φ6 (1/4")	12g per meter added	(Total length of pipe run – 5 meters) x 12 g
Φ9.52 or Φ9 (3/8")	24g per meter added	(Total length of pipe run – 5 meters) x 24 g

## OIL RETURN ELBOW

When the height difference between the indoor and outdoor unit is greater than 5m, in order to allow oil to return to the compressor, an oil return elbow must be used. See diagrams below for examples:

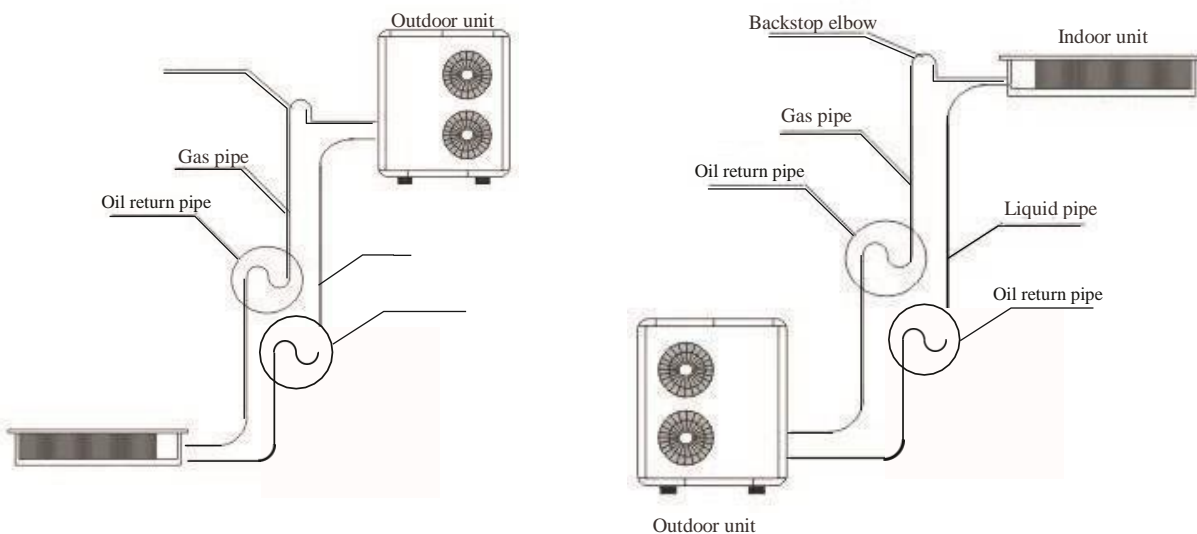

If oil return elbow radius  $R \leq 100\text{mm}$ , oil return elbows must be located per 5 m as shown; when the height difference between indoor and outdoor unit exceeds five meters, oil reserve elbow and backstop elbow should be set according to the relative position of outdoor unit and indoor unit. Make sure that the copper pipes are not kinked or bent.

### GAS LEAKAGE INSPECTION

After the pipeline connection is done, use a leakage inspection device to carefully check if there is any leakage at the joints. This is an important step to ensure the quality of installation. Once a leak is detected, proper action should be taken immediately.





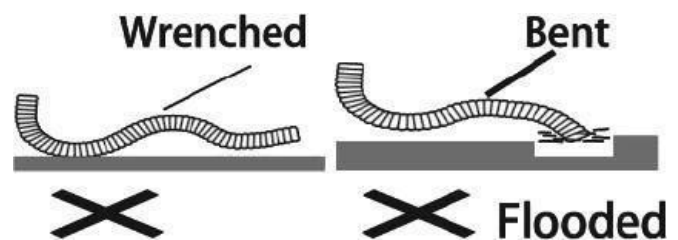
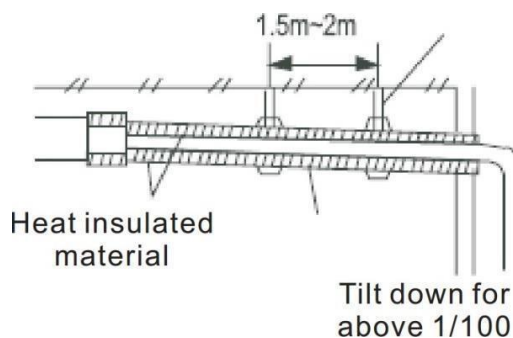



### INSTALL THE WATER DRAINAGE PIPE

1. For good drainage, the drain hose should be angled downwards.
2. Do not pull on or bend the drain hose or flood its end with water.
3. Use inline pumps for water uplift or if the water drain pipe is very long
4. When the long drainage hose passes through indoor areas, it should be wrapped in insulation.

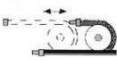
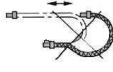

**NOTES:**

The copper pipe used in the refrigeration lines is very soft, high pressure copper and prone to get damaged if not handled correctly. Try to avoid getting it bent or stretched. Always use foam protectors (sleeve) and a plastic ring before getting the pipes through the wall. Those will help prevent damage to the pipes.

<p>To keep the allowed bending radius please make the packed soft pipes vertical before</p>			<p>Please do not extend only one side of the packed soft pipes.</p>
<p>Please make use of semicircle pulley to keep the allowed bending angle</p>			<p>Extreme bending could damage the pipes</p>
<p>Please use a twisting wheel to avoid improper bending.</p>			<p>Over bent soft pipes will lead to irregular bending</p>
<p>Please use rigid elbow to keep the bending angle while soft pipes operating.</p>			<p>Undersize bending will damage the soft pipe.</p>
<p>Please keep the minimum bending angle while installing</p>			<p>Do not use short sharp angle bends.</p>



## ELECTRICAL WIRING DIAGRAMS

For ease of installation the indoor unit of most models will be provided pre wired with 5 metres of interconnecting cable.

**eiQ-FC18K**

**eiQ-FC24K**

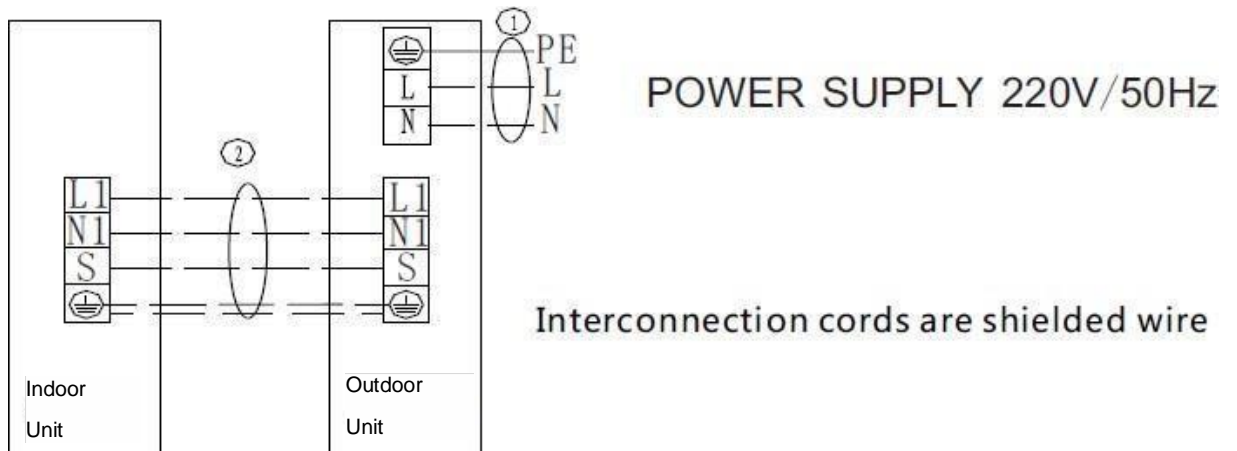

**eiQ-FC36K**

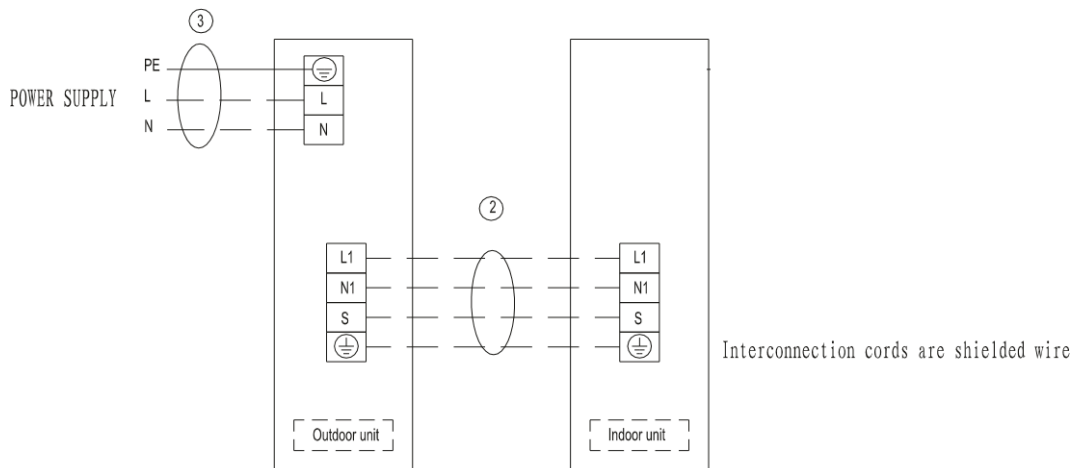

## CONNECTION OF ELECTRICAL POWER AND SIGNAL CABLES

Only allow qualified engineers that can follow local regulations to install the equipment and the power.

**Warning:** The air conditioner unit must be securely grounded!

If the power cord or signal cable of the appliance is damaged, it must be replaced with a new cord with same or better specifications.

Dedicated power cable should be used on the air conditioner. Also overload protection circuits may be used as necessary.

Ensure wiring is correctly performed and connections are tested

All wiring should be connected correctly according to the electrical wiring schematic, incorrect wiring will cause the air conditioner to operate incorrectly or be damaged.

Never alter the wiring inside the air conditioner or perform unauthorised service.

### CONNECTION OF THE POWER CORD

Supply the power to both indoor / outdoor units following the wiring diagrams in this manual. Where discrepancies are found between the diagram within the manual, and the circuit diagrams on the unit, the information provided on the appliance must be followed.

### SIGNAL CABLE

Attention must be paid when performing wiring operations, to avoid air conditioner malfunction due to electromagnetic interference.

- (1) The signal cable shall be separated from the power supply line and outdoor and indoor connection line;
- (2) If the air conditioner is installed in a place susceptible to interference, it is best to use shielded wire and twisted pair as signal cable or for the wired remote control

Model	Outdoor power supply line, qty, diameter	Indoor power supply line, qty, diameter	Indoor / outdoor signal line	Power supply method
eiQ-FC18	3 x 2.5mm <sup>2</sup>	N/A	4 x 2.5mm <sup>2</sup>	Outdoor power supply
eiQ-FC24	3 x 2.5mm <sup>2</sup>	N/A	4 x 2.5mm <sup>2</sup>	Outdoor power supply
eiQ-FC36	3 x 4mm <sup>2</sup>	N/A	4 x 2.5mm <sup>2</sup>	Outdoor power supply.

## TROUBLESHOOTING AND SELF DIAGNOSIS

electriQ air conditioners have an advanced self-diagnosis system allowing them to display the service information

### Indoor unit error code list

Check	Description	Display Code (unit & remote)	Unit Display Status
			Display LED (light flashing)
Indoor parts	Three-phase power phase sequence fault	E0	
	Indoor and out unit communication failure	E1	Timing lights flash
	Temperature sensor (T1) fault	E2	Running lights flash
	Pipe temperature sensor in the evaporator (T2) fault	E3	Running lights flash
	Pipe temperature sensor in the evaporator (T2B) fault	E4	Running lights flash
	Outdoor unit failure	E5	Warning lights flash slowly
	The indoor unit EEPROM fault	E7	Defrost lights flash slowly
	Water over protection	EE	Warning lights flash
	Indoor Unit with line controller communication failure	E9	

## OUTDOOR UNIT ERROR CODE LIST

Display	Error description	Display	Error description
E0	Phase protection	F0	(reserved)
E1	Communication error between outdoor unit and indoor unit	F1	(reserved)
E2	Indoor room temperature (T1) sensor error	F2	(reserved)
E3	Indoor coil middle temperature (T2) sensor error	F3	Outdoor unit current error cannot recover Display P3 error for 3 times within 60 minutes
E4	Indoor coil outlet temperature (T2B) sensor error	F4	Outdoor temperature (T4) sensor error
E5	Outdoor unit error	F5	(reserved)
E6	Zero speed protection	F6	Outdoor unit condenser outlet (T3) sensor error
E7	EERPOM error	F7	Secondary side current protection
E8	Indoor fan motor speed lose protect ion	F8	Heat T2 temp. protection
E9	Wired controller communication error	F9	Outdoor unit voltage error
EE	Water level alarm error		
EF	(reserved)		

Display	Error description	Display	Error description
P0	(reserved)	H0	Communication error between outdoor unit main board and driver board
P1	(reserved)	H1	(reserved)
P2	(reserved)	H2	(reserved)
P3	Primary/secondary overcurrent protection	H3	(reserved)
P4	Exhaust temperature over-high protection	H4	3 times of P6 error within 30 minutes
P5	Outdoor unit condenser outlet (T3) temperature over-high protection	H5	3 times of P2 error within 30 minutes
P6	Compressor driver error or IPM protection	H6	3 times of P4 error within 100 minutes
P7	(reserved)	H7	(reserved)
P8	(reserved)	H8	(reserved)
P9	Outdoor unit DC fan motor error	H9	2 times of P9 error within 10 minutes

**Notes:** If the unit is faulty the POWER ON LED will be on and the display LED will flash the corresponding number of times as shown in the table. Both LEDs will go off for 2 seconds then cycle will repeat. Although the above diagnostic information is commonly applicable in most air conditioners, there may be exceptions, please contact the service centre for help.

## DIAGNOSTIC AND MAINTANCE CODES

The digital led display in the indoor unit display number of units connected in the system while in standby; also displays the frequency value during operation of compressor. During defrost on cold days the LED light displays “dF”. There is a service codes check button on outdoor unit PCB, pressing this button different times will check and display the following codes:

	Codes	Notes																	
Normal display	Current frequency / number of indoor units in the system	Displays the operating inverter frequency and number of indoor units in the system (for multisplit units)																	
1	Outdoor unit local capacity	for 18K/24K/36K outdoor unit, it shows 53/70/105, (5.3/7.1/10.5 Kw) for 48K outdoor unit, it shows 5 (5HP)																	
2	Identify installed indoor unit capacity	The following codes will be displayed 6=eiq-FC18K, 9=eiq-FC24K, 12= eiq-FC36K,15= eiq-FC48K (to find the approx. 1,000s BTU value multiply by 3 or divide by 3 for HP)																	
3	Variable DC inverter current operating capacity factor (adjusted from outdoor unit requirements T4)	<p>eiq-FC18K = 5.3kw, eiq-FC24K= 7.1kw, eiq-FC36K= 10.5kw, eiq-FC48K=14kw. The kw is converted approximatively to hp in the pcb logic as 5.3kw= 2HP, 7.1kw= 3HP, 10.5kw= 4HP, 14kw= 5HP. If for eiq-FC18K e.g. max capacity is measured as 3xHP=6 (A) as in code (2). The variable DC inverter operating capacity is calculated as per table below. So if T4 is 22 C than the variable operating capacity is 80% of 6 rounded to integer 6x80%=4.8 the display will show 5. For the same unit if T4 is 16C than the unit will display 3 (rounded up from 2.4).</p> <table border="1"> <thead> <tr> <th rowspan="2">Cooling mode</th> <th colspan="5">Outdoor unit temperature</th> </tr> <tr> <th>T4 ≤ -6</th> <th>-6 &lt; T4 ≤ 17</th> <th>17 &lt; T4 ≤ 25</th> <th>25 &lt; T4 ≤ 50</th> <th>50 &lt; T4</th> </tr> </thead> <tbody> <tr> <td>Variable DC inverter operating capacity factor</td> <td>0</td> <td>40%*A</td> <td>80%*A</td> <td>100%*A</td> <td>0</td> </tr> </tbody> </table>	Cooling mode	Outdoor unit temperature					T4 ≤ -6	-6 < T4 ≤ 17	17 < T4 ≤ 25	25 < T4 ≤ 50	50 < T4	Variable DC inverter operating capacity factor	0	40%*A	80%*A	100%*A	0
Cooling mode	Outdoor unit temperature																		
	T4 ≤ -6	-6 < T4 ≤ 17	17 < T4 ≤ 25	25 < T4 ≤ 50	50 < T4														
Variable DC inverter operating capacity factor	0	40%*A	80%*A	100%*A	0														
4	Operation mode (0: Off / fan only; 2: cooling; 3: heating; 4: forced cooling);	<p>0 Compressor <b>OFF</b>            2-4 Compressor <b>ON</b></p>																	
5	Variable DC inverter current operating capacity factor (adjusted from indoor unit requirements T2B)	<p>Similar to (3) but the adjustment is also done according to the indoor evaporator temperature sensor T2B. So if for example in (3) if outdoor temp T4 is 22° and T2B is decreasing from and T2B is decrease from 8°C to 6°C than the real output capacity needed is adjusted to 5-1=4</p>																	
6	Fan status	Different numbers means different fan speeds.																	

		for 18-36K, it will show 0-7 it's according to outdoor unit DC motor variable speed for 48K, it shows always 0 due to fixed speed AC motor
7	T2/T2B average temperature	T2 evaporator / T2B evaporator outlet temperature (Celsius)
8	T3 pipe temperature	T3 condenser outlet temperature (Celsius)
9	T4 environmental temperature	Outdoor temperature (Celsius)
10	T5 exhaust temperature	Compressor discharger temperature (Celsius)
11	Opening of the EEV	Displays electronic expansion valve opening. The valve has 500 steps from close position. The display will show from 0 (20) to 60 (500) which is the valve step divided by 8
12	Primary current (AC)	Primary circuit load (Amps)
13	Secondary circuit current (AC)	Secondary circuit load (Amps)
14	Primary voltage (DC)	Primary circuit voltage (V) (to find actual value multiply by 4)
15	Secondary voltage (DC)	Secondary circuit voltage (V)
16	Sets of indoor units	Would show 0/1 for indoor unit not installed 1/1 for 1 indoor unit installed
17	Number of active indoor units	0(/1) for indoor unit not working 1(/1) for indoor unit working
18	Last fault or protection code	Display the last error code
19	Code check over	Pressing again returns to normal operation mode

## TECHNICAL SPECIFICATIONS

Model			eiQ-FC18K-V2	eiQ-FC24K-V2
Power supply		V/Ph/Hz	220~240/1/50	220~240/1/50
Cooling	Capacity	KW	2.0-5.3-5.6	3.5-7.0-8.0
	Power input	W	420-1640-2100	600-2200-3000
	Current input	A	2.1-10.1	2.5-13
	EER	W/W	3.23	3.18
	SEER	W/W	6.1	6.1
Heating	Capacity	KW	2.5-5.9-6.0	4.5-7.7-8.5
	Input	W	500-1530-1940	1500-1980-2600
	Rated current	A	2.5-9.2	5.5-11
	COP	W/W	3.86	3.89
	SCOP	W/W	4.0	4.0
Energy rate		Cooling	A++	A++
Energy rate		Heating	A+	A+
Max. power input		W	2400	3200
Max. current input		A	11.4	14
Indoor fan motor	Model		DR-310-120LD-8	DR-310-120LD-8
	Brand		Panasonic	Panasonic
	Power output	W	120	120
	Capacitor	μ F	-	-
	Speed	r/min	1400	1400
	Insulation class		E	E
Indoor coil	Number of rows		2	3
	Tube pitch(a)xrow pitch(b)	Mm	21×13.37	21×13.37
	Fin spacing	Mm	1.4	1.4
	Fin type		Hydrophilic	Hydrophilic
	Tube outside dia. and type	mm	Φ7	Φ7
			inner grooved	inner grooved
	Coil length x height x width	mm	1000x252x26.74	1000x252x40.11
Number of circuits		2	4	
Indoor air flow (High speed)		m <sup>3</sup> /h	900/800/650	1150/1000/850
Indoor noise level	power level	dB(A)	46~58	53~60
	pressure level		36/42/47	43/46/49
Indoor unit	Dimension (W*H*D)	Body(mm)	1245x680x240	1245x680x240
	Packing (W*H*D)	Body(mm)	1325x770x325	1325x770x325
	Net/Gross weight	Body(Kg)	34/40	35/41
Max pressure		MPa	4.5	4.5
Refrigerant type			R32 / 1300g	R32 / 1700g
Refrigerant piping	Liquid side/Gas side	mm	Φ6.35/Φ12.7	Φ9.52/Φ15.88
Drainage pipe		mm	DN25	DN25
Operation temp		°C	16~32	16~32
Ambient temp	Cooling	°C	-15~50	-15~50
	Heating	°C	-15~30	-15~30



Model			<b>eIQ-FC36K-V2</b>
Power supply		V/Ph/Hz	220~240/1/50
Cooling	Capacity	KW	6.6-10.5-12.8
	Power input	W	740-3170-3900
	Current input	A	2.8-13.6-20
	EER	W/W	3.31
	SEER	W/W	6.1
Heating	Capacity	KW	7.35-11.5-13.2
	Input	W	1100-3395-4000
	Rated current	A	4.2-14.7-20.4
	COP	W/W	3.39
	SCOP	W/W	4.0
Energy rate		Cooling	A++
Energy rate		Heating	A+
Max. power input		W	4800
Max. current input		A	26
Indoor fan motor	Model		DR-310-120LD-8
	Brand		Panasonic
	Power output	W	120
	Capacitor	μF	-
	Speed	r/min	1400
	Insulation class		E
Indoor coil	Number of rows		3
	Tube pitch(a)xrow pitch(b)	mm	21×13.37
	Fin spacing	mm	1.4
	Fin type		Hydrophilic
	Tube outside dia. and type	mm	Φ7 inner grooved
	Coil length x height x width	mm	1000x252x40.11
	Number of circuits		4
Indoor air flow (High speed)		m <sup>3</sup> /h	1800/1650/1500
Indoor noise level	power level	dB(A)	56~65
	pressure level		45/48/51
Indoor unit	Dimension (W*H*D)	Body(mm)	1245×680×240
	Packing (W*H*D)	Body(mm)	1325×770×325
	Net/Gross weight	Body(Kg)	35/41
Max pressure		MPa	4.5
Refrigerant type			R32 / 2150g
Refrigerant piping	Liquid side/Gas side	mm	Φ9.52/Φ15.88
Drainage pipe		mm	DN25
Operation temp		°C	16~32
Ambient temp	cooling	°C	-15~50
	heating	°C	-15~30

### WARRANTY INFORMATION

**electriQ** guarantee provides cover against material or manufacturing faults. This means that if your air conditioner develops a fault during the guarantee period, we will arrange for it to be repaired or replaced. Faults arising from a faulty installation are specifically excluded. The system must be serviced annually by qualified personnel. This unit must be operated under conditions as recommended in this user manual, at voltages indicated on the unit. Any attempts made to service or modify the unit by unqualified person, will render this WARRANTY VOID.

This warranty is in addition to, and does not affect, your statutory rights. Our warranty is RTB warranty and cover parts and labour only.

We recommend that you note the details of your purchase below and retain your original proof of purchase receipt with this manual. Keep these documents safe in the event of a warranty claim.

Purchase Date: \_\_\_\_\_

Retailer name: \_\_\_\_\_

Model number: \_\_\_\_\_

Serial number: \_\_\_\_\_

Installation Date: \_\_\_\_\_

Installer name: \_\_\_\_\_

Service Date: \_\_\_\_\_

Engineer/ Companyname: \_\_\_\_\_

## APPENDIX

Disposal: Do not dispose this product as unsorted waste. Collection of such waste must be handled separately as special treatment is necessary.



Recycling facilities are now available for all customers at which you can deposit your old electrical products. Customers will be able to take any old electrical equipment to participating sites run by their local councils. Please remember that this equipment will be further handled during the recycling process, so please be considerate when depositing your equipment. Please contact the local council for details of your local household waste recycling centres.



### WARNING

- Do not use means to accelerate the defrosting process or to clean, other than those recommended by the manufacturer.
- The appliance shall be stored in a room without continuously operating ignition sources (For example: open flames, an operating gas appliance or an operating electric heater)
- Do not pierce or burn.
- Be aware that refrigerants may not contain an odour.

### electriQ UK SUPPORT

[www.electriQ.co.uk/support](http://www.electriQ.co.uk/support)

Please, for your own convenience, check the troubleshooting guide before calling the service line.

If the unit still fails to operate call: 0871 620 1057 or complete the online form

Office hours: 9AM - 5PM Monday to Friday

www.electriQ.co.uk  
Unit J6, Lowfields Business Park  
Lowfields Way, Elland  
West Yorkshire, HX5 9DA